

# Panasonic®

NETWORK  
CAMERA

## Network Color Dome Camera WV-NS324



www.Rock2000.com  
Toll Free: 1-888-919-2263  
Outside the U.S.: +1-845-343-4077  
Fax: +1-845-343-4299



## OUR NEW BROADBAND CAPABLE AND SURVEILLANCE FEATURE-PACKED COLOR DOME CAMERA

The new Panasonic WV-NS324 can be connected to both analog and digital networks. Color camera, zoom lens, pan and tilt mechanisms are all combined in a single compact unit. When this camera is connected to an Ethernet network, you can operate it and monitor its images from a personal computer. Or, you can use it with an analog color composite signal as part of your existing surveillance systems using coaxial cable. With input from a motion detector or external sensor, it can automatically store images and attach them to e-mail or control external devices to turn on lights or start surveillance recording. Combining a 10x zoom lens with 5x digital zoom, it can zoom in for up to 50x close-ups. It operates in lighting as low as 1.0 lx (0.1 fc) and can pan a full 360°. The Flip-A-Chip feature makes it easy to capture subjects passing directly below the camera, the image-hold feature prevents blurring when the camera moves, and pre-set positions simplify operation.

Superb specifications and a host of convenience features make the WV-NS324 ideal for bank branch, franchise outlet or other network surveillance applications.

### OPTIONAL ACCESSORIES

Smoke Cover  
**WV-CS2SH**  
Mirror Cover  
**WV-CS2M**



### KEY FEATURES

- Compact dome designed all-in-one unit color surveillance camera.
- Both analog video output and digital Ethernet port are available.
- Built-in network interface (10Base-T/100Base-TX) for remote monitoring by PC simply. (Internet interface protocol; TCP/IP, UDP/IP, HTTP, FTP, SMTP, DNS, DDNS, DHCP, NTP and BOOTP)
- Built-in Alarm function for external security devices, and FTP alarm activation.
- JPEG image size : VGA (640 x 480), HVGA (640 x 240), QVGA (320 x 240) and QQVGA (160 x 120)
- 1/4 -type CCD color image sensor with 768H x 494V pixels.
- 480-line of horizontal resolution.
- Min. illumination of 1.0 lx (0.1 fc) (at AGC High).
- Built-in Flip-A-Chip function.
- Image hold function during panning.
- 360° endless panning range.
- Auto panning with rotation speed of 100°/s.
- 10x optical zoom (4.2 - 42mm at F1.4) plus 5x electronic digital zoom lens provided (total zoom capacity of 50x).
- Auto focus lens mechanism.
- Alarm input/output terminal connectors
- Built-in digital motion detector.
- Built-in alphanumeric character display.
- Electronic sensitivity enhancement (Auto; up to 10x, Manual; up to 32x, and Off)
- Digital signal processing LSI's for high quality pictures : 2H vertical enhancement, Chroma gain, Pedestal, Hue and Noise reduction circuit.
- Multiplexed Vertical Drive (VD2) sync capability with Panasonic system products.
- AC 24V power supply for easy installation.

## SYSTEM EXAMPLES

### 1 Monitoring System utilizing an Intranet

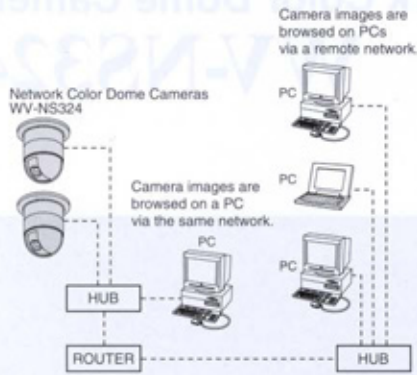

### 2 Monitoring with Panasonic System Products

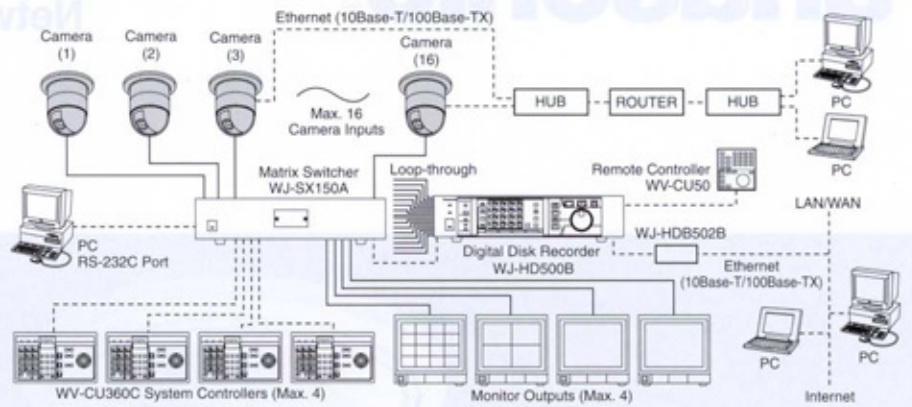

## SPECIFICATIONS

Pick-up Device	768 (H) x 494 (V)
Scanning Area	3.65mm (H) x 2.71mm (V), 1/4-type CCD image sensor
Synchronization	Internal/Line-Lock/Multiplexed Vertical Drive (VD2)
Scanning	525 lines/60 fields/30 frames
Scanning System	2 : 1 interlace
Video Output	VBS1.0V[p-p]75Ω, composite signal
Resolution	H more than 480 lines (at center) V more than 350 lines (at center)
Minimum Illumination	1.0 lx (0.1 fc) at F1.4 (at AGC High)
Signal to Noise Ratio	50dB (AGC OFF, Weight On)
AGC	On (Low, Mid, High)/Off
Title Display	On/Off
Motion Detector	On/Off
Flip-A-Chip Function	On/Off
BLC	Selectable On/Off
Set Up	Max. 4 times, Auto/Fix
Alarm Input	2 Inputs (Alarm In 1-2)
Alarm Output	2 Outputs (Alarm/Aux)
Electronic Shutter	Off (1/60), 1/100, 1/250, 1/500, 1/1,000, 1/2,000, 1/4,000, 1/10,000 s
Network Section	
Image Resolution	VGA (640 x 480), HVGA (640 x 240), QVGA (320 x 240) and QQVGA (160 x 120)
Image Process	JPEG (Super Fine/Fine/Normal/Rough selectable)
Image Refresh Rate	Fast/Middle/Slow/Very Slow
Traffic Control	32/64/128/256/512/1,024 kbps and unlimited
Internet Protocol	TCP/IP, UDP/IP, HTTP, FTP, SMTP, DNS, DDNS, DHCP, NTP and BOOTP
Zoom Ratio	10x Optical plus 5x digital zoom (50x total)
Max. Aperture Ratio	1 : 1.4 (Wide) - 2.0 (Tele)
Focal Length	4.2 - 42mm
Angular Field of View	H 4.9° - 47° V 3.7° - 36°
Zoom Speed	approx. 3.9s (Tele/Wide) in manual mode
Focus Speed	approx. 3.0s (Far / Near) in manual mode
Iris	Automatic (open/close)/manual
Panning Range	360° endless
Panning Angle Setting	Possible (in auto-pan mode)
Panning Mode	Manual/auto pan
Panning Speed	Manual: approx. 1.0°/s ~ 100°/s Preset position: max. 100°/s
Tilting Range	0° - 92°
Tilting Mode	Manual
Tilting Speed	Manual: approx. 1.0°/s ~ 100°/s Preset position: max. 100°/s
Controls	Pan/tilt, lens, preset position, home position
Controller I/F	Multiplex-Coaxial
Power Supply	24V AC, 60Hz
Power Consumption	15W
Ambient Operating Temperature	-10°C - 50°C (14°F - 122°F)
Ambient Operating Humidity	Less than 90%
Dimensions	ø120 (D) x 196 (H) mm [ø4-3/4" (D) x 7-11/16" (H)] (ø110mm [ø4.3"] diameter dome size)
Weight	Approx. 2kg (4.4lbs.)

## MAJOR OPERATING CONTROLS

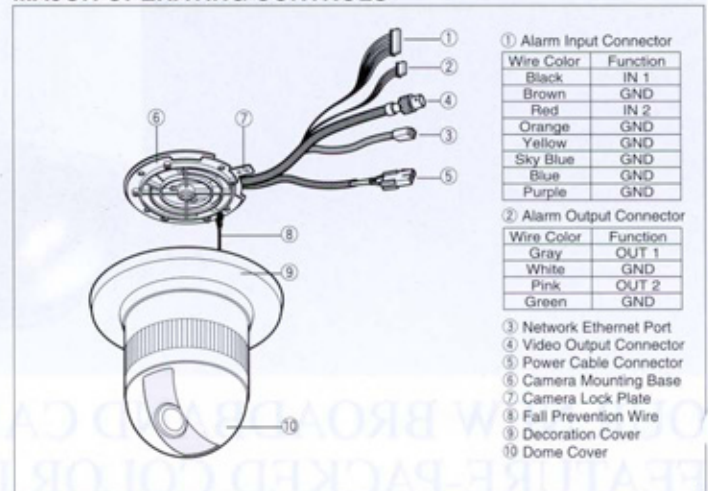

## APPEARANCE

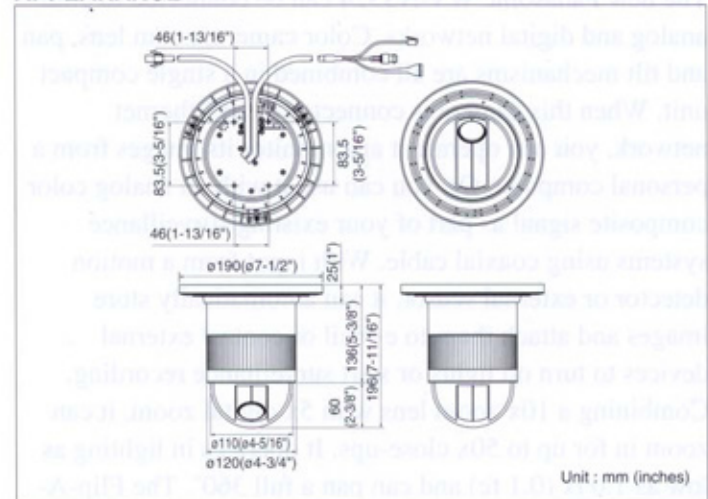

• Weights and dimensions are approximate. • Specifications are subject to change without notice. • These products may be subject to export control regulations.

# Panasonic

Panasonic Digital Communications & Security Company

Unit of Matsushita Electric Corporation of America

Security Systems Group

<http://www.panasonic.com/cctv>

Executive Office : One Panasonic Way 3E-7, Secaucus, New Jersey 07094

Zone Office

Eastern : One Panasonic Way, Secaucus, NJ 07094 (201) 348-7303

Central : 1707 N.Randal Road, Elgin, IL 60123 (847) 468-5205

Western : 6550 Katella Ave., Cypress, CA 90630 (714) 373-7840

DISTRIBUTED BY:



RHP INTERNATIONAL, INC. - [www.Rock2000.com](http://www.Rock2000.com)  
PO BOX 4242  
MIDDLETOWN, NY 10941

Toll Free: 1-888-919-2263  
Outside the U.S.: +1-845-343-4077  
Fax: +1-845-343-4299

PANASONIC CANADA INC.

5770 Ambler Drive, Mississauga, Ontario, L4W 2T3 Canada (905) 624-5010

PANASONIC SALES COMPANY

DIVISION OF MATSUSHITA ELECTRIC OF PUERTO RICO, INC.

San Gabriel Industrial Park 65th Infantry Ave. KM. 9.5 Carolina, P.R. 00985 (809) 750-4300

Printed in Japan  
WV-JHNS324T(2P-507)